

For liquids and gases

KE® Rubber Expansion Joints

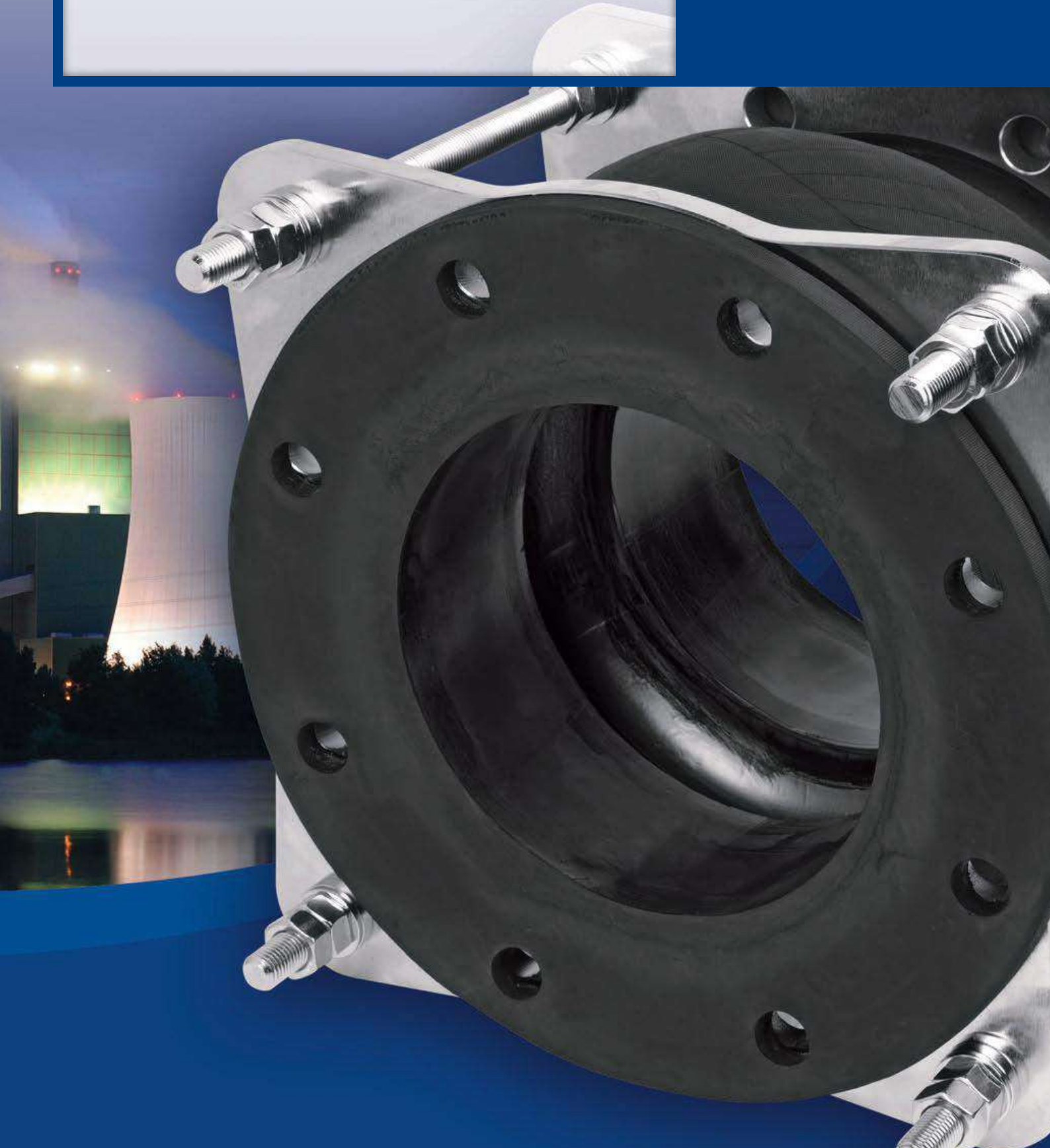

EagleBurgmann®

expansion joint solutions

Value Engineering raised on global experience

Over 45 years of challenges in the expansion joint industry proves that EagleBurgmann Expansion Joint Solutions is one of the worlds most experienced and innovative expansion joint manufacturers.

Experience is sourced from all continents and various market sectors to provide our customers with the latest technologies and solutions.

Metal, fabric and rubber expansion joints are flexible connections, installed in piping and ducting systems to accommodate expansion and vibration caused by changes in temperature, pressure and media comprise.

EagleBurgmann Expansion Joint Solutions major focuses:

- Value engineering to decrease operational downtime
- Lean manufacturing to reduce costs
- 3D smart design to maximize overall service life

EagleBurgmann Expansion Joint Solutions comprehensive service:

- Evaluations and troubleshooting
- Initial dimensional measurements
- Installation and refurbishment
- Supervision and training
- Plant surveys
- Emergency services
- Final inspection by experienced Service Engineers

EagleBurgmann Expansion Joint Solutions is approved to:

- European Pressure Equipment Directive (PED) 97/23/CE
- ASME, Section VIII, Div. 1, U2
- UOP recommended manufacturer
- ISO 3834-2:2006
- ISO 9001:2008 by Bureau Veritas
- Environmental, Health & Safety ISO 14001:2004 and OHSAS 18001:2008 by Bureau Veritas
- AD 2000-Merkblatt

EagleBurgmann Expansion Joint Solutions is a respected member of:

- The European Sealing Association (ESA)
- Fluid Sealing Association (FSA)
- Expansion Joint Manufacturers Association (EJMA)
- Euro-Qualiflex

EagleBurgmann Expansion Joint Solutions is proud of the appreciation given from hundreds of customers around the world.

EagleBurgmann Expansion Joint Solutions has global production in:

- Europe
- Americas
- Asia Pacific

We have a worldwide sales network supported by EagleBurgmann and Freudenberg offices.

www.eagleburgmann-ej.com



- P4.** KE® Rubber Expansion Joints Basics Design
- P5.** KE® Rubber Expansion Joints D-Type
- P6.** KE® Rubber Expansion Joints DFS-Type
- P7.** KE® Rubber Expansion Joints Engineering
- P10.** Water Treatment
- P11.** Cooling Applications
- P12.** Special Applications
- P13.** Certificates and Tests
- P14.** Installation, Service and Preventive Maintenance
- P15.** Complete Line of Expansion Joint Solutions

EagleBurgmann.
expansion joint solutions

**Innovation
Technology
Customized solutions**

KE® Rubber Expansion Joints Basics Design

KE® Rubber Expansion Joints

are flexible connectors made from natural or synthetic elastomers in which special fabrics are embedded to provide physical reinforcement.

KE® Rubber Expansion Joints provide a proven and flexible solution to accommodate all types of movements and requirements of industrial plants and equipment. The KE® high pressure rubber expansion joint can be made from different rubber materials depending on media and application. They are designed to take up axial, lateral, angular and torsional movements along with vibrations in piping.

Dimensions: DN20-DN3600

Temperature range: From -50 °C up to 160 °C

Pressure: Full vacuum to 2.500 kPag

KE® Rubber Expansion Joints advantages:

- Accommodates pressure loads
- Neutralises axial, lateral, angular and torsional stresses
- Reduces noise
- Isolates sources of vibration
- Easy to install
- Compensates for misalignment
- Prolongs life of motive equipment
- Gaskets or packing are not needed
- Absorbes pulsation of fluid, preventing water hammering to some extent

KE® Rubber Expansion Joints are used in piping systems that transports fluids, slurries or gases under pressure, or under vacuum in a wide range of temperatures.

Application Areas:

- Air conditioning, heating and ventilating systems in industrial buildings and vessels
- Central and ancillary power generating stations in industrial buildings, factories, ships and off-shore applications
- Sewage disposal and water treatment plant, pumps, etc.
- Process piping in pulp and paper plants
- Piping systems for chilled or hot water in industrial plants
- Cooling systems for power generation
- Feed water and draining lines for water works, sewage, sanitary piping systems etc.
- Oil lines for industrial plants, shipyards, phosphate plants etc.
- Potable water applications
- Food applications

Axial elongation (+) ↔ (+)



Axial compression (-) →← (-)



Lateral offset (+) ↑↓ (-)



Angular offset (+) ↘↙ (-)



EagleBurgmann
expansion joint solutions

KE® Rubber Expansion Joints D-Type

Standard solution for
standard applications

KE® D-Type Rubber Expansion Joints

are high quality standard rubber expansion joints, in a single sphere molded design, available in dimensions ranging from DN20 to DN750.

KE® Rubber D-Type Expansion Joints are available in all standard rubber materials and for special applications also in certified rubber material approved for food and drinking water. D-Types are available in standard lengths following the most common international standards.

The D-Type is designed with solid floating flanges. Depending on the application, they can be carbon steel electroplated, hot dip galvanized or stainless steel AISI 316TI as standard. The rubber is molded with a raised face design and can be mounted on either a raised face or on full face pipe flanges.

Flanges are as standard drilled to DIN PN10, PN16 and ANSI 150 lbs, other drilling patterns are available on request.

To limit the movements of the expansion joint, or to reduce loads on piping system, KE® Rubber D-Type Expansion Joints can be delivered with tie-rods with either loose or integrated brackets.

For application down to full vacuum, a vacuum ring can be installed to support the rubber expansion joint. D-Type rubber expansion joints are typically used in applications like heating and ventilation, pump inlet and discharge, transportation of solids etc.

D-Type vacuum rating

Nominal dimension of pipe	Positive pressure	Negative pressure (*)
20-300 mm	1600 kPag	-50 kPag
350-500 mm	1000 kPag	-50 kPag
550-750 mm	800 kPag	-50 kPag

(*) Without vacuum ring. For design incorporating full vacuum, please contact EagleBurgmann Expansion Joint Solutions.

D-Type with tie rods and floating flanges

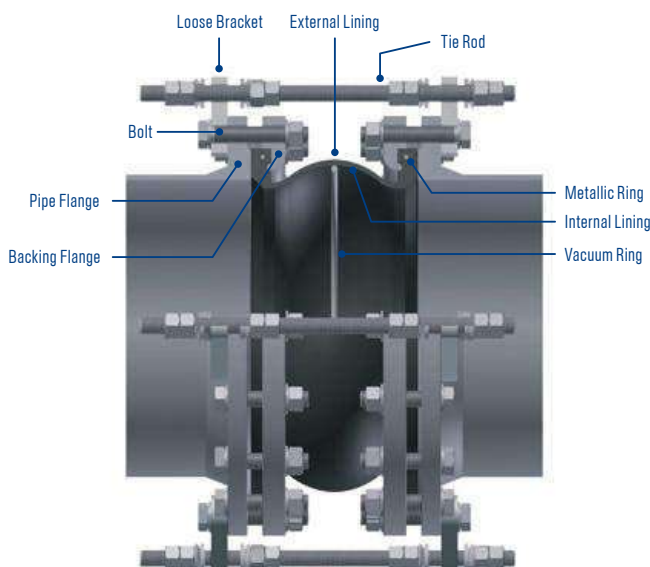

D-Type size, pressure and movements

DN Ø	Short Length (mm)	Long Length (mm)	Working Pressure kPa(G)	Short Axial Compression	Long Axial Compression	Short Axial Elongation	Long Axial Elongation	Lateral	Angular
20-40	130	150	1600	30	35	15	20	20	25
50-80	130	150	1600	30	35	15	20	20	20
100	130	150	1600	30	35	15	20	20	15
125-150	130	150	1600	30	35	15	20	20	10
200	130	150-200	1600	30	35	15	20	20	8
250-300	130	200	1600	30	40	15	20	20	6
350	130	200	1000	30	40	15	20	20	6
400-450		200	1000		40		20	20	5
500		200	1000		40		20	20	5
600		250	800		40		20	20	4
650-750		250	800		40		20	20	3

EagleBurgmann.
expansion joint solutions

Custom made
Large sizes
Multiple arch

KE® Rubber Expansion Joints DFS-Type

KE® Rubber DFS-Type

Expansion Joints are high quality handmade “spool arch” vulcanized rubber expansion joints available in dimensions ranging from DN50-DN3600.

KE® Rubber DFS-Type Expansion Joints are available in all standard rubber materials and for special applications also in certified rubber material approved for food and drinking water. DFS-Types are custom made. In the case of large movements in the application, multiple arch design can be provided to allow for large axial and lateral movements.

As standard, DFS-Types are supplied with full face split flanges in carbon steel. DFS-Types are also available with full flange design (one piece). In case of raised face piping flange, spacer rings must be used to install full face joints. Flanges are as standard drilled to DIN PN10, PN16, ANSI 150 lbs, ANSI AWWA 207 class B, ANSI AWWA 207 class D, other drilling patterns are available on request.

All DFS-Types can be designed with control units (tie rods, spherical washers etc.) to control movements of the expansion joints or forces within the piping system. For all designs with tie rods, steel flanges are designed with integrated brackets with a safety factor 1.5 times the design pressure given by the

customer. The design of DFS-Types permits a vacuum to -50 kPag without installing a vacuum ring. For a higher vacuum, rings can be installed in materials resistant to media (standard AISI 316TI, SMO 254, AISI 904L).

KE® DFS-Type Rubber Expansion Joints are typically used in:

- Cooling
- Desalination
- Flue gas cleaning
- Power generating stations
- Sewage disposal and water treatment plants
- Pumps
- Process piping in pulp and paper
- Chemical Plants

Customized product:

- Build lengths
- Flange drilling
- Tie-rod design

Special features (optional):

- High pressure
- Multiple arch
- Reducer design

DFS-Type size, pressure and movements

DN Ø	Length mm	Working Pressure kPa(G)	Axial Compress.	Axial Elongation	Lateral	Angular
50-950	200-300	1000	40	15	30	6
1000-1150	300-350	800	40	15	30	6
1200-1500	350	800	40	15	30	6
1600-2100	350	600	40	15	30	4
2200-2250	350	600	40	15	30	4
2400-3600	350	300	40	15	30	3

DFS-Type with tie rods and split flanges

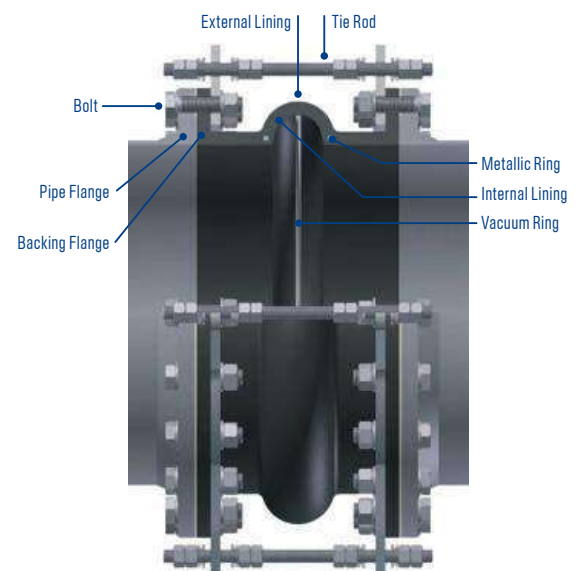

EagleBurgmann
expansion joint solutions

KE® Rubber Expansion Joints Engineering

Pressure thrust
Spool arch
Narrow arch

KE® Rubber DFS-Type Expansion Joints

all engineered products are designed to the actual specifications for:

- Movements
- Temperature
- Pressure / pressure loads
- Media
- Neutralising axial, lateral, angular and torsional forces
- Vibrations, pulsation and friction
- Misalignment
- External applied loads
- Corrosive environment

Pressure and temperature

As standard KE® Rubber Expansion Joints are designed with polyester reinforcement fabric. For application where high temperature and high pressure

occur at the same time, alternative high temperature rubber (HT) and reinforcement fabric can be used.

Tie rods

Expansion joints extend in length when pressurized, and must be constrained within their rated length. The force generated by this internal pressure is described as "The Pressure Thrust". Where the pipe supports and anchors are not designed to absorb this force, tie rods across the joint must be specified.

Total movement

It is important that the total of static and dynamic movements does not exceed the rated movement capability specified for the joint. Where the dynamic movement frequency and amplitude are high, the joint pressure rating should be reduced in proportion.

Pressure loads

KE® Rubber Expansion Joints can be designed to withstand pressures of up to 1600 kPag. They can be engineered for even higher pressures if desired, depending on the combination of operating temperature, movement and pressure, caused by operating equipment or processes in the piping system.

KE® DFS-Type

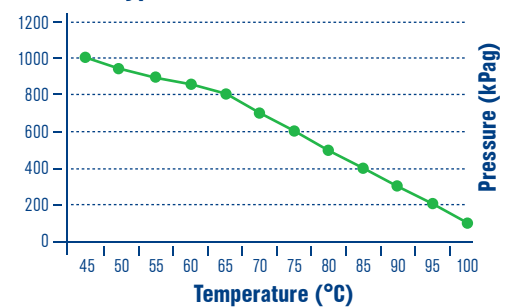

Material chart

Color dots	Material	Main Application	Max temp.*
● Grey	Neoprene	Sea water, water cooling systems	107°C
● Red	EPDM	Hot water, heating and cooling systems	121°C
● Yellow/Red	EPDM HT	Hot water and steam, heating and cooling systems	150°C
● White/Red	EPDM WRAS 60	Potable water, drinking water	60°C
● Yellow	Nitrile	Resistant to oil and gas	99°C
● Green	Hypalon®	Strong acids, except nitric acid or sulphuric acid	121°C
● Red/Red	FKM	High temperatures, products derived from petroleum	160°C
○ White	Nitrile	Food conduction, potable water supply	90°C
● Blue	Butyl	Suitable for alkaline waste, compressed air (oil free) and chemicals, weather resistant	121°C
● White/Blue	Butyl HT	Good heat resistance, suitable for alkaline waste, compressed air (oil free), chemicals and special hydraulic oils, weather resistant	150°C
● White/Green	Natural Rubber	High abrasive media	82°C

(* Temperature resistance is dependent on system pressure. Chemical resistance guide for elastomers is available on request. Other rubber types such as natural rubber etc. can be supplied on request.

Vacuum ring chart

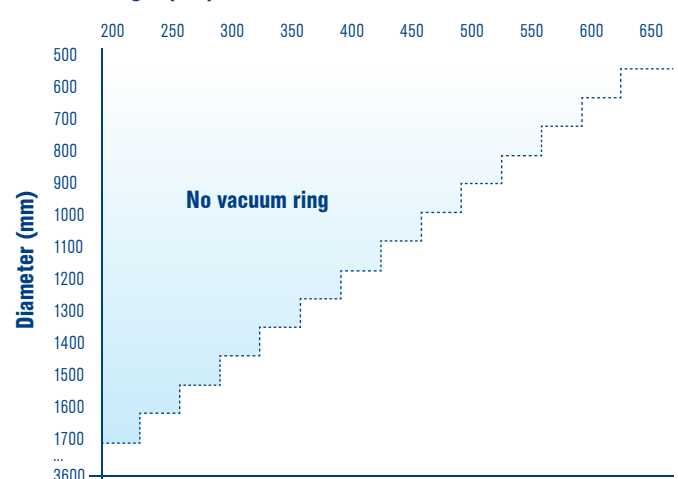

EagleBurgmann®

expansion joint solutions

We can take the heat and the pressure

From major water distribution pipelines spanning the high desert to specially designed pressure balanced units in cooling systems, EagleBurgmann Expansion Joint Solutions are installed in thousands of applications worldwide. Whether it is air, gas, petrochemicals or water, our expansion joints are designed to provide maximum reliability and safety. Our technical expertise and progressive manufacturing capabilities enable us to offer our customers solutions that increase overall service life, reduce costs and decrease operational downtime. EagleBurgmann Expansion Joint Solutions – making business sense!

Innovative expansion joints solutions – to meet the worlds pipe expansion needs





EagleBurgmann
expansion joint solutions

**Desalination
WRAS approval
Sewage systems**

Water Treatment

Water Treatment

KE® Rubber Expansion Joints are installed in all water treatment processes in pipes and ducts as flexible connections to compensate for thermal expansion, vibration and misalignment under high pressure.

KE® Rubber Expansion Joints are the right choice for waste water treatment applications. No matter if the media contains solids, abrasive slurry or regular waste water, EagleBurgmann Expansion Joint Solutions has a design for all challenges. For highly abrasive media, an inner sleeve of wear resistant material can be installed to prevent the rubber expansion joint

from being directly exposed to abrasion. For applications with aggressive media operating under vacuum rings of AISI materials suitable to the media are used in the design. In cases that expansion joints are installed in high corrosive environment, the joints can be supplied with AISI stainless steel flanges and tie-rods, alternatively high quality anti-corrosive surface treatment can be applied.

For the desalination process

KE® Rubber Expansion Joints are the right choice for applications on the water intake side as well as on the potable water side. For the water intake system

KE® Rubber Expansion Joints in Neoprene or EPDM are the excellent choice to handle seawater, and designed with integrated brackets and tie-rods. They will meet all design requirements from the pipe system with regards to loads.

On the potable water side

WRAS approved rubber is used to manufacture drinking water approved expansion joints to ensure that water will not be contaminated. WRAS approved rubber expansion joints are available in D-Types and DFS-Types depending on design specifications.



KE® Rubber Expansion Joint for Water Treatment.



KE® Rubber Expansion Joint in Major Pipelines.



KE® Rubber Expansion Joint DFS-Type.

EagleBurgmann
expansion joint solutions

Cooling Applications

HVAC
GRP design
District cooling

KE® Rubber Expansion Joints

are installed worldwide in district cooling, pipelines for seawater supply, recycling in cooling towers, HVAC and other cooling applications. KE® Rubber Expansion Joints are installed to absorb the movements, vibrations etc. in connection with pumps, valves etc.

GRP Piping

For seawater applications where GRP piping is used, we have designed expansion joints to meet the specification for low loads. Especially at the connecting flange area the GRP requires a special designs to

reduce the forces on the flange. Reduced mechanical strength in GRP flanges, especially where tie-rods are installed in the expansion joint requires alternative designs.

The preferred GRP flanges

are either stub flanges with steel backing rings or fixed flanges fitted with a steel backing ring to support the GRP material. The expansion joint steel flanges are designed as full flange (one piece). Compared to the normal split flange design this ensures an equal force all around the GRP flange area. Assisted by

in-house Finite Element Analysis, we have developed designs that significantly reduce damaging loads on the GRP flange, compared to standard expansion joint designs.

EagleBurgmann Expansion Joint Solutions is original manufacturer of the

KE® Rubber Expansion Joints and have the required engineering skills in-house to understand customers demands and design accordingly. For engineering tools, FEA and 3D modelling are used.



GRP 3D Model.



GRP Cooling Water Piping.



Solar Plant Cooling.

EagleBurgmann
expansion joint solutions

Protection
Pulp and paper
Pressure balanced

Special Applications

KE® Rubber Expansion Joints

can be designed as hoses for special pipe systems, such as pulp and paper plants. Rubber hoses are installed in the part of feed pipes which transports the pulp to the paper making machine.

Rubber hoses must be completely smooth at the inside surface, in order not to stop the flow of the very fine particles in media. Rubber hoses are designed up to 1000 kPag and can absorb movements of ± 100 mm axial.

In-line pressure balanced

expansion joints absorbs axial movement and/or lateral deflection while restraining the pressure thrust

on the system. This is achieved by means of tie devices interconnecting the line bellows with outboard compensating bellows that are also subjected to line pressure.

Each bellows set is designed

to absorb axial movement and the line bellows will usually absorb lateral deflection. Pressure forces are not generated in a piping system with expansion joints, when this construction is used as the volume changes in the piping system are of equal value.

Pressure balanced expansion joints are employed where the location of the expansion joint prohibits or makes it expensive to install main anchors.

Protection

MA-1: Fire protection approved for marine and offshore industry by Bureau Veritas.

Splash Guard

Protection of environment and employees against pressurized leaking fluids and protection of the bellow from impact damage.

Sun Cover

Protection against UV radiation. When expansion joints are installed in high UV radiant areas, it is advisable to use sun covers.



Pressure Balanced Rubber Expansion Joint 3D modelling.



3D Engineering of KE® Rubber Expansion Joint.



KE® Rubber Hose for pulp and paper.

Certificates and Tests

PED
Pressure test
Type approval

Certificates:

- ISO 9001:2008
- ISO 14001:2004
- OHSAS 18001:2008
- Safety hoods (Marine)
- Drinking Water (WRAS)
- Food Industry

Tests

- Hydraulic tests
- Tensile strength
- Temperature resistance
- Burst strength
- Cycle life
- Reaction forces

- Abrasion resistance
- Compression testing
- Pressure Equipment Directive (PED) 97/23/EC
- Bureau Veritas' Type Approval Certificate no. 12823/AO BV (Fire resistance)

PED

For the categorising, please inform below information:

- Type of fluid
- Group (According to PED Directive art. 9)
- Group 1: Dangerous (explosive, extremely flammable, highly flammable or flammable (where the maximum allowable temperature is above flashpoint))
- Group 2: All other fluids not referred to above

KE® Safety Hoods

are specially designed as a cover and protection of rubber expansion joints in case of (1) special operating conditions outside requiring extra protection against outside influence as fire, strokes, sharp objects, or similar and/or (2) flow of dangerous media inside requiring extra protection of the environment due to the risk of possible leakage.

Certificates, tests and other documentation are available on request.



Hydraulic Pressure Testing.



EagleBurgmann Expansion Joint Solutions holds a varied range of approvals and certificates.



KE Safety Hoods.



EagleBurgmann
expansion joint solutions

Improve reliability
Increase service life
Worldwide service teams

Installation, Service and Preventive Maintenance

Servicing our customers is core competence of EagleBurgmann Expansion Joint Solutions

Operational reliability: long service life of expansion joint is crucial as unplanned shut downs are not only troublesome – but also expensive. The right installation can save hundreds of man-hours by a correct and safe installation.

Service is a part of our core business

Reliability and long service life is essential for our customers! EagleBurgmann Expansion Joint Solutions offers Field Service: 24/7/360. We can assist you in your expansion joint challenges.

Safety has the highest priority

of EagleBurgmann Expansion Joint Solutions – both for our manufacturing and installation personnel, but

also for users of our products. The safety of all employees and personnel working on your plant or refinery is our greatest concern.

Our service teams complete routine internal training in safety and certification training to ensure that each team member observes current industry safety practices as well as site specific policies and procedures.

- Emergency services
- Final inspection and experienced Service Engineers

EagleBurgmann Expansion Joint Solutions comprehensive service includes:

- Evaluations and troubleshooting
- Initial dimensional measurements
- Installation and refurbishment
- Supervision and training
- Plant surveys

24 hours hotline:

Fabric, Metal and Rubber Expansion Joints:

Tel. +45 2124 6632

Fabric Expansion Joints (USA):

Tel. +1(859) 746 0091

Metal Expansion Joints (USA):

Tel. +1(619) 562 6083



Preparation for installation of KE® Rubber Expansion Joint.



Installation of KE® Rubber Expansion Joint.



Retorquing of KE® Rubber Expansion Joint.



Complete Line of Expansion Joint Solutions

Fabric
Rubber
Metal



 KE® Fabric Expansion Joints.



 KE® Rubber Expansion Joints.

KE® Fabric Expansion Joints

are installed as flexible connections in air and flue gas pipe and duct systems to take up or compensate for thermal expansion, vibrations and misalignments. KE® Fabric Expansion Joints take up movements in several directions simultaneously, have almost no reactive forces, need little space for installation, are easy to adapt to existing physical conditions, and they are easy to transport and install.

KE® Rubber Expansion Joints

KE® Rubber Expansion Joints are flexible connectors made from natural or synthetic elastomers in which special fabrics are embedded to provide physical reinforcement. A proven and flexible solution to accommodate many types of movements and requirements of industrial plant and equipment. Used in systems transporting fluids, slurries or gases under pressure, at ambient pressure or under vacuum over a wide range of temperatures.



 Bredan® Metal Expansion Joints.

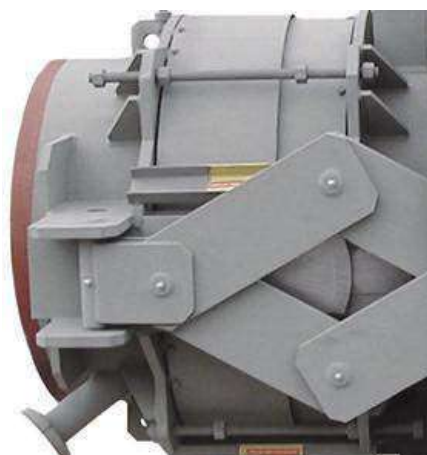

 EJS® Metal Expansion Joints.

Bredan® and EJS® Metal Expansion Joints

EagleBurgmann Expansion Joint Solutions offers a full range of Bredan® and EJS® metal expansion joints from round and rectangular ducting expansion joints to highly engineered expansion joints to serve customers in the power generation, oil and petrochemical, pulp and paper, industrial and heavy equipment suppliers and a variety of OEM markets.

EagleBurgmann Expansion Joint Solutions is a world leader in the industry with installations found in thousands of plants worldwide with a long history of welding and forming of special materials including a wide range of nickel alloys. EagleBurgmann Expansion Joint Solutions offers complete documentation packages to the latest industry standards.

Argentina · Australia · Austria · Belarus · Belgium · Bulgaria · Brazil · Canada · Chile · China · Colombia · Cyprus · Czech Republic · Denmark · Ecuador · Egypt · Estonia
 Finland · France · Germany · Great Britain · Greece · Hungary · India · Indonesia · Iraq · Israel · Italy · Japan · Jordan · Kazakhstan · Korea · Kuwait · Latvia · Libya · Lithuania
 Malaysia · Mauritius · Mexico · Morocco · Myanmar · Netherlands · New Zealand · Nigeria · Norway · Oman · Pakistan · Paraguay · Peru · Philippines · Poland · Qatar
 Romania · Russia · Saudi Arabia · Singapore · Slovenia · Slovak Republic · South Africa · Spain · Sweden · Switzerland · Syria · Taiwan · Thailand · Trinidad and Tobago · Tunisia
 Turkey · Turkmenistan · Ukraine · United Arab Emirates · Uruguay · USA · Uzbekistan · Venezuela · Vietnam · www.eagleburgmann.com/world



EagleBurgmann Expansion Joint Solutions is a leading global organization in the development of expansion joint technology; working to meet the challenges of today's ever-changing environmental, quality and productivity demands. Our flexible products are installed in thousands of plants, refineries and on equipment worldwide where reliability and safety are key factors for operating success. As part of the international organization EagleBurgmann Group, more than 5000 employees contribute their ideas, solutions and commitment to ensure our customers worldwide can rely on our products and services.

For more information – visit eagleburgmann-ej.com and eagleburgmann.com.

EagleBurgmann Middle East FZE



sales@ae.eagleburgmann.com

EagleBurgmann®
 expansion joint solutions